

SECTION 1 - SPECIFICATIONS

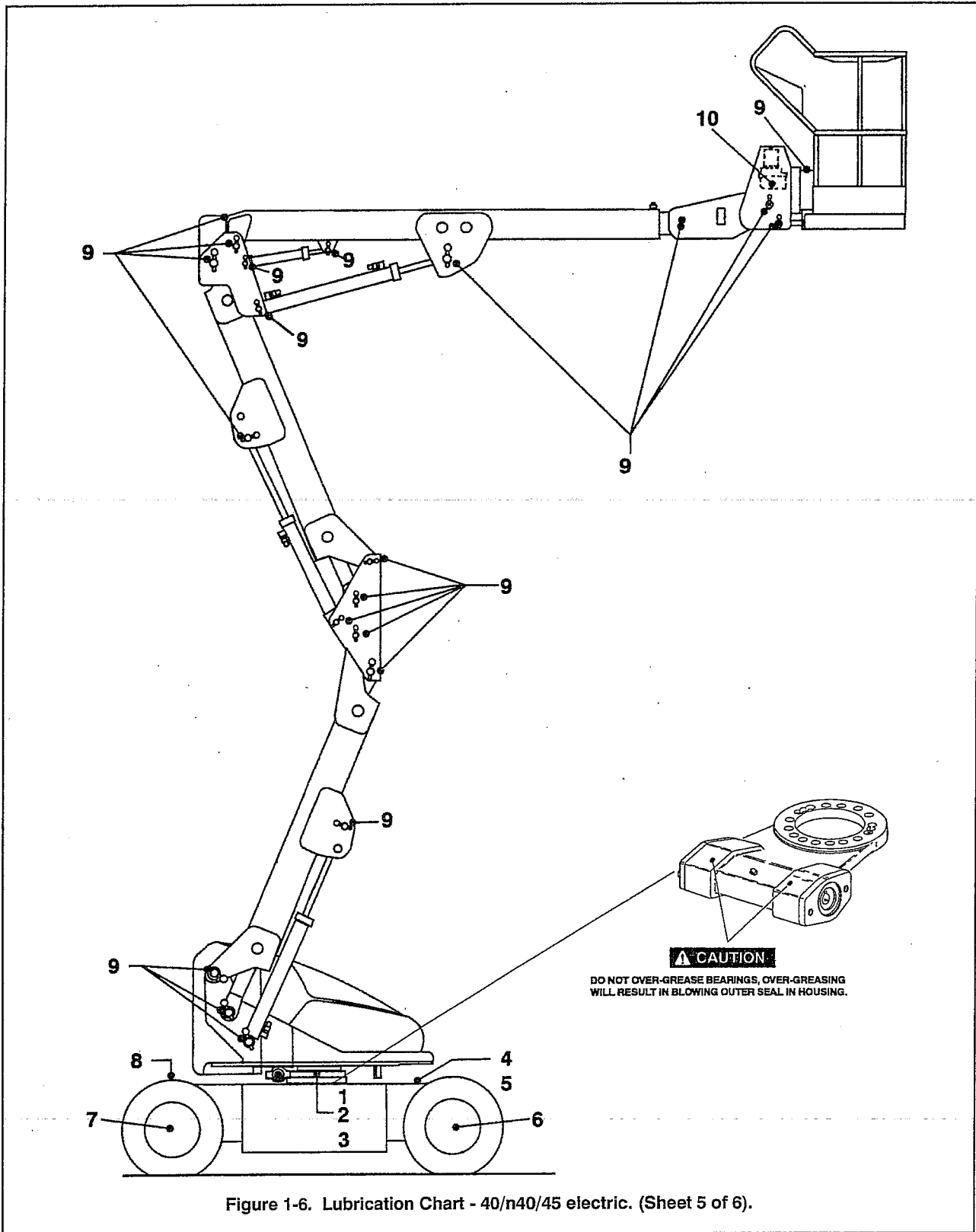

COMPONENTS	NUMBER/TYPE LUBE POINTS	CAPACITY	LUBE	INTERVAL			HOURS	COMMENTS
				3 MONTHS 150 HRS	6 MONTHS 300 HRS	1 YEAR 600 HRS		
<b>LUBRICATION:</b>								
1 Swing Bearing	1 Grease Fitting	A/R	BG/MPG	✓				BG will have a longer service interval than MPG.
2 Swing Bearing - Gear - Teeth *	1 Grease Fitting	A/R	OG/MPG	✓				OG will have a longer service interval than MPG.
3 Swing Worm Gear - Bearing	Plug	A/R	BG/MPG				✓	BG will have a longer service interval than MPG.
4 Hydraulic Fluid (Oil)	Fill Cap	4.0 Gals Tank 4.8 Gals System	HO				✓	Check oil every 10 hours of operation. Change oil every 1200 hours of operation.
5 Hydraulic Filter	N/A	N/A	N/A			✓		Replace filter element after first 50 hours and every 300 hours thereafter.
6 Wheel Drive Hub	Fill Plug/located at 4 or 8 O'clock	12 OZ. (approx)	EPGL	✓				Check oil level at side plug on hub.
7 Wheel Bearing	Repack	A/R	MPG				✓	
8 Spindles/Bushing	N/A	A/R	LL					At spindle/bushing replacement.
9 Boom Pivot Pins/Bushing	N/A	A/R	LL					At boom pivot pins/bushing replacement.
10 Rotator Hydraulic Tank	Fill Cap	1 Quart.	HO				✓	Check oil every 10 hours of operation. Change oil every 1200 hours of operation.
<b>NOTE:</b>								
Lubrication intervals are based on machine operation under normal conditions. For machines used in multi shift operations and/or exposed to hostile environments or conditions, lubrication frequencies must be increased accordingly.				* If necessary install grease fittings into worm gear housing and grease bearings. Read CAUTION on diagram before greasing.				<b>KEY TO LUBRICANTS:</b> BG - Mobilith SHC 460 Bearing Grease. EPGL - Extreme Pressure Gear Lube. HO - Hydraulic Oil - Mobilfluid 424 or Kendall Hyken 052. LL - Synthetic Lithium Lubricant (Gredag 741 Grease). MPG - Multi-Purpose Grease. OG - Open Gear Lube (Tribol Molub-Alloy Grease)

Figure 1-7. Lubrication Chart - 40/n40/45 electric. (Sheet 6 of 6).

## SECTION 1. SPECIFICATIONS

**1.1 CAPACITIES.****Hydraulic Oil Tank.**

4.0 gallons (15.14 liters).

**Hydraulic System.**

Approximately 4.8 gallons (18.2 liters).

Torque Hubs (2).

17 ounces (0.5 liters).

**1.2 COMPONENT DATA.****Battery Charger.**

Input, 110 VAC, 60 HZ.

Output, 48 VDC (23 Amps.).

Batteries (8).

6 Volt, 370 AmpHour (20 hour rate).

**Drive System.**

Drive Motor - 36 VDC, 4.1 H.P. @ 1880 rpm. continuous, rotation - reversible.

Drive Brake- 24 VDC, spring-applied, electrically released.

Tires - 30 electric.

Tires - ST205 75R15, Load Range C, 6 Ply Rating, 70 psi (4.9 kg/cm<sup>2</sup>).

Foam Filled - 205 75R15, 6 Ply Rating, 70 psi (4.9 kg/cm<sup>2</sup>).

Solid Tires - 26 x 7 x 20 Lug Tread Non marking Compound. (Optional)

Tires - n35/n40 electric.

Solid Tires - 22 x 6 x 16 Lug Tread Dual Service Compound.

Solid Tires - 22 x 6 x 16 Lug Tread Non marking Compound. (Optional)

Tires - 35/40 electric. (Prior to March of 1996)

Tires - ST225 75R15, Load Range D, 8 Ply Rating, 80 psi (5.5 kg/cm<sup>2</sup>).

Tires - ST225 75R15, Load Range D, 8 Ply Rating, Foam Filled. (Optional)

Tires - 35/40 electric. (March of 1996 to Present)

Tires - G 78 - 15, Load Range E, 10 Ply Rating, 80 psi (5.5 kg/cm<sup>2</sup>).

Tires - G 78 - 15, Load Range E, 10 Ply Rating, Foam Filled. (Optional)

Solid Tires - 22 x 6.5 x 16 Lug Tread Non marking Compound. (Optional)

Tires 10 - 16.5 NHS, 8 Ply, 70 psi (4.9 kg/cm<sup>2</sup>).

Tires 10 - 16.5 NHS, 8 Ply, 70 psi (4.9 kg/cm<sup>2</sup>), Foam Filled

Tires - 45 electric.

Tires - LT215 85R16, Load Range E, 10 Ply Rating, 90 psi (6.2 kg/cm<sup>2</sup>).

Tires - LT215 85R16, Load Range E, 10 Ply Rating, Foam Filled. (Optional)

Tires 10 - 16.5 NHS, 8 Ply, 70 psi (4.9 kg/cm<sup>2</sup>).

Tires 10 - 16.5 NHS, 8 Ply, 70 psi (4.9 kg/cm<sup>2</sup>), Foam Filled.

**Hydraulic Filter.**

Return, 10 Micron.

**Hydraulic Pump/Electric Motor Assembly.**

Motor - 48 VDC, 2.14 H.P. @ 2700 rpm.

Pump - 0.098 in.<sup>3</sup>/rev. (1.6 cm<sup>3</sup>/rev.).

Pump Output - 1.09 gpm (4.13 lpm) @ 2000 psi (137.9 Bar).

**1.3 PERFORMANCE DATA.**

EE Rated, Certified By U/L.

**Travel Speed.**

30 electric - 4 mph (6.4 kph).

35 electric - 3 mph (4.8 kph).

n35 electric - 2.5 mph (4.1 kph).

40 electric - 3 mph (4.8 kph).

n40 electric - 2.5 mph (4.1 kph).

45 electric - 2.6 mph (4.2 kph).

## SECTION 1 - SPECIFICATIONS

---

### **Gradeability.**

---

25%

### **Maximum Slope**

---

5%.

### **Turning Radius (Inside).**

---

30 electric - 4 ft. 4.50 in. (1.33 m.).

35 electric - 4 ft. 3 in. (1.31 m.).

n35 electric - 5 ft. 3 in. (1.60 m.).

40 electric - 4 ft. 3 in. (1.31 m.).

n40 electric - 5 ft. 3 in. (1.60 m.).

45 electric - 4 ft. 3 in. (1.31 m.).

### **Turning Radius (Outside).**

---

30 electric - 11 ft. 10 in. (3.63 m.).

35 electric - 11 ft. 10 in. (3.63 m.).

n35 electric - 11 ft. 10 in. (3.63 m.).

40 electric - 11 ft. 10 in. (3.63 m.).

n40 electric - 11 ft. 10 in. (3.63 m.).

45 electric - 11 ft. 10 in. (3.63 m.).

### **Upper Boom Speed.**

---

30 electric - Lift Up - 15 - 25 seconds.

30 electric - Lift Down - 17 - 27 seconds.

35/n35 electric - Lift Up - 40 - 50 seconds.

35/n35 electric - Lift Down - 32 - 42 seconds.

40/n40 electric - Lift Up - 40 - 50 seconds.

40/n40 electric - Lift Down - 59 - 69 seconds.

45 electric - Lift Up - 40 - 50 seconds.

45 electric - Lift Down - 39 - 49 seconds.

### **Lower Boom Speed.**

---

30 electric - Lift Up - 16 - 26 seconds.

30 electric - Lift Down - 19 - 29 seconds.

35/n35 electric - Lift Up - 49 - 59 seconds.

35/n35 electric - Lift Down - 30 - 40 seconds.

40/n40 electric - Lift Up - 50 - 60 seconds.

40/n40 electric - Lift Down - 23 - 29 seconds.

45 electric - Lift Up - 58 - 68 seconds.

45 electric - Lift Down - 28 - 38 seconds.

### **Swing Speed - 360 Degrees.**

---

30 electric - 55 - 65 seconds.

35/n35 electric - 65 - 75 seconds.

40/n40 electric - 85 - 95 seconds.

45 electric - 85 - 95 seconds.

### **Machine Weight.**

---

30 electric - 4,770 lb. (2,164 kg).

35 electric - 9,500 lb. (4,309 kg).

n35 electric - 10,200 lb. (4,627 kg).

40 electric - 10,700 lb. (4,853 kg).

n40 electric - 11,830 lb. (5,366 kg).

45 electric - 11,800 lb. (5,352 kg).

### **Max. Tire Load.**

---

30 electric - 2560 lbs. (1,161 kg).

35 electric - 3580 lbs. (1,624 kg).

n35 electric - 4250 lbs. (1,928 kg).

40 electric - 4700 lbs. (2,132 kg).

n40 electric - 5600 lbs. (2,540 kg).

45 electric - 5850 lbs. (2,656 kg).

### **Machine Height (stowed).**

---

30 electric - 6 ft., 7.0 in. (2.0 m.).

35/n35 electric - 6 ft., 7.0 in. (2.0 m.).

40/n40 electric - 6 ft., 7.0 in. (2.0 m.).

45 electric - 6 ft., 7.0 in. (2.0 m.).

### **Machine Length (stowed).**

---

30 electric - 15 ft., 7.0 in. (4.75 m.).

35/n35 electric - 17 ft., 0 in. (5.18 m.).

40 electric - 17 ft., 7.0 in. (5.36 m.).

n40 electric - 17 ft., 4 in. (5.28 m.).

45 electric - 18 ft., 8.0 in. (5.69 m.).

**Up and Over Platform Height.**

- 30 electric - 16 ft.,7.0 in. (5.05 m.).
- 35/n35 electric - 17 ft.,11.0 in. (5.46 m.).
- 40/n40 electric - 20 ft.,0 in. (6.10 m.).
- 45 electric - 24 ft.,7 in. (7.49 m.).

**Horizontal Reach Up and Over.**

- 30 electric - 13 ft.,5.0 in. (4.09 m.).
- 35/n35 electric - 20 ft.,6.0 in. (6.25 m.).
- 40/n40 electric - 20 ft.,6.0 in. (6.25 m.).
- 45 electric - 22 ft. 8 in.,(6.91 m.).

**Machine Width.**

- 30 electric - 5 ft.,9 in. (1.75 m.).
- 35 electric - 5 ft.,9 in. (1.75 m.).
- n35 electric - 4 ft.,11 in. (1.50 m.).
- 40 electric - 5 ft.,9 in. (1.75 m.).
- n40 electric - 4 ft.,11 in. (1.50 m.).
- 45 electric - 5 ft.,9 in. (1.75 m.).

**Wheel Base.**

- 30 electric - 6 ft., 4 in. (1.93 m.).
- 35/n35 electric - 6 ft., 7.25 in. (2.01 m.).
- 40/n40 electric - 6 ft., 7.25 in. (2.01 m.).
- 45 electric - 6 ft., 7.25 in. (2.01 m.).

**Working Height.**

- 30 electric - 30 ft., 0 in. (9.14 m.).
- 35/n35 electric - 35 ft., 0 in. (10.67 m.).
- 40/n40 electric - 40 ft., 0 in. (12.19 m.).
- 45 electric - 45 ft., 0 in. (13.72 m.).

**1.4 TORQUE SPECIFICATIONS.**

Table 1-1.Torque specifications

Description	Torque Value (Dry)	Interval Hours
A. Bearing To Chassis	See Note	50/600*
B. Bearing To Turntable	See Note	50/600*
C. Wheel Bolts	90 ft. lb. (122 Nm)	150***

**NOTE:** \*Check swing bearing bolts for security after first 50 hours of operation and every 600 hours thereafter. (See paragraph 2-16, - Swing Bearing.)

**NOTE:** \*\*\*Torque in cross pattern. Foam filled or solid tires may require more frequent torque intervals.

**NOTE:** When maintenance becomes necessary or a fastener has loosened, refer to the Torque Chart, Figure 1-1, to determine proper torque value.

## SECTION 1 - SPECIFICATIONS

### 1.5 LUBRICATION.

#### Hydraulic Oil.

Table 1-2. Hydraulic Oil

HYDRAULIC SYSTEM OPERATING TEMPERATURE RANGE	SAE VISCOSITY GRADE
0 F to 23 F (-18 C to -5 C)	10W
0 F to 210 F (-18 C to +99 C)	10W-20, 10W-30
50 F to 210 F (+10 C to +99 C)	20W-20

**NOTE:** Hydraulic oils must have anti-wear qualities at least to API Service Classification GL-3, and sufficient chemical stability for mobile hydraulic system service. JLG Industries recommends Mobilfluid 424 hydraulic oil, which has an SAE viscosity index of 152.

**NOTE:** Aside from JLG recommendations, it is not advisable to mix oils of different brands or types, as they may not contain the same required additives or be of comparable viscosities. If use of hydraulic oil other than Mobilfluid 424 is desired, contact JLG Industries for proper recommendations.

#### Lubrication Specifications

Table 1-3. Lubrication Specifications

KEY	SPECIFICATIONS
MPG	Multipurpose Grease having a minimum dripping point of 350 F (178 C). Excellent water resistance and adhesive qualities, and being of extreme pressure type. (Timken OK 40 pounds minimum.)
EPGL	Extreme Pressure Gear Lube (oil) meeting API service classification GL-5 or MIL-Spec MIL-L-2105.
HO	Hydraulic Oil. API service classification GL-3, e.g. Mobilfluid 424.
OG*	Open Gear Lube - Mobiltac 375NC, Aerosol spray. (JLG Part No. 3020036)
BG*	Bearing Grease (JLG Part No. 3020029) Mobilith SHA 460.
LL	Synthetic Lithium Lubricant, Gredag 741 Grease. (JLG Part No. 3020022)

\*MPG may be substituted for these lubricants, if necessary, but service intervals will be reduced.

**NOTE:** Refer to Lubrication Chart, Figure 1-2, for specific lubrication procedures.

### 1.6 PRESSURE SETTINGS.

- Model 30 electric.

#### Hydro-Air Valve 4640725.

Lift Down Relief - 900 psi (62 bar).

Articulate and Lift Down Relief - 725 psi (49.99 bar).

Swing Relief - 1000 psi (68.95 bar).

#### Hydro-Air Valve 4640726.

Steer Relief - 1100 psi (75.84 bar).

Main Relief at Pump - 2600 psi (179.27 bar).

- Model 35/n35 electric.

#### Hydro-Air Valve 4640843.

Upper Lift Down Relief - 600 psi (41.37 bar).

Lower Lift Down Relief - 600 psi (41.37 bar).

Swing Relief - 1000 psi (68.95 bar).

Telescope In Relief - 2150 psi (148.25 bar).

Platform Level Up Relief - 2500 psi (172.37 bar).

Platform Level Down Relief - 1200 psi (82.74 bar).

#### Hydro-Air Valve 4640726.

Steer Relief - 1500 psi (103.42 bar).

Main Relief at Pump - 2600 psi (179.27 bar).

- Model 40/n40/45 electric.

#### Hydro-Air Valve 4640797.

Upper Lift Down Relief - 650 psi (44.82 bar).

Mid/Lower Lift Down Relief - 1700 psi (117.21 bar).

Swing Relief - 1000 psi (68.95 bar).

Telescope In Relief - 2150 psi (148.25 bar).

Platform Level Up Relief - 2500 psi (172.37 bar).

Platform Level Down Relief - 1200 psi (82.74 bar).

#### Hydro-Air Valve 4640726.

Steer Relief - 1500 psi (103.42 bar).

Main Relief at Pump - 3200 psi (220.64 bar).

**1.7 CYLINDER SPECIFICATIONS.**

**NOTE:** All dimensions are given in inches (in.), with the metric equivalent, millimeters (mm) given in parentheses.

**Table 1-4. Cylinder Specifications.**

e30			
DESCRIPTION	BORE	STROKE	ROD DIA.
Upper Lift Cylinder	3.00 (76.2)	14.62 (371.5)	1.50 (38.1)
Lower Lift Cylinder	3.00 (76.2)	14.62 (371.5)	1.50 (38.1)
Steer Cylinder (Double Rod)	2.00 (50.8)	3.00 (76.2) each direction	1.25 (31.8) each rod
e35/n35e			
DESCRIPTION	BORE	STROKE	ROD DIA.
Upper Lift Cylinder	3.00 (76.2)	24.4375 (620.7)	1.50 (38.1)
Lower Lift Cylinder	3.50 (88.9)	25.375 (644.5)	2.00 (50.8)
Telescope Cylinder	2.00 (50.8)	79 (2006.6)	1.25 (31.8)
Master Cylinder	2.00 (50.8)	9.375 (238.1)	1.00 (25.4)
Slave Cylinder	2.00 (50.8)	9.375 (238.1)	1.00 (25.4)
Rotator Cylinder	1.875 (47.6)	15.250 (387.3)	1.00 (25.4)
Steer Cylinder (Double Rod)	2.00 (50.8)	3.00 (76.2) each direction	1.25 (31.8) each rod
e40/n40e			
DESCRIPTION	BORE	STROKE	ROD DIA.
Upper Lift Cylinder	3.00 (76.2)	28.3125 (719.1)	1.50 (38.1)
Mid Lift Cylinder	3.00 (76.2)	21.25 (539.7)	1.50 (38.1)
Lower Lift Cylinder	3.50 (88.9)	23.1875 (589.0)	2.00 (50.8)
Telescope Cylinder	2.00 (50.8)	79 (2006.6)	1.25 (31.8)

**Table 1-4. Cylinder Specifications.**

Master Cylinder	2.00 (50.8)	9.375 (238.1)	1.00 (25.4)
Slave Cylinder	2.00 (50.8)	9.375 (238.1)	1.00 (25.4)
Rotator Cylinder	1.875 (47.6)	15.250 (387.3)	1.00 (25.4)
Steer Cylinder (Double Rod)	2.00 (50.8)	3.00 (76.2) each direction	1.25 (31.8) each rod
e45			
DESCRIPTION	BORE	STROKE	ROD DIA.
Upper Lift Cylinder	3.00 (76.2)	28.3125 (719.1)	1.50 (38.1)
Mid Lift Cylinder	3.00 (76.2)	21.25 (539.7)	1.50 (38.1)
Lower Lift Cylinder	3.50 (88.9)	23.1875 (589.0)	2.00 (50.8)
Telescope Cylinder	2.00 (50.8)	79 (2006.6)	1.25 (31.8)
Master Cylinder	2.00 (50.8)	9.375 (238.1)	1.00 (25.4)
Slave Cylinder	2.00 (50.8)	9.375 (238.1)	1.00 (25.4)
Rotator Cylinder	1.875 (47.6)	15.250 (387.3)	1.00 (25.4)
Steer Cylinder (Double Rod)	2.00 (50.8)	3.00 (76.2) each direction	1.25 (31.8) each rod

**1.8 MAJOR COMPONENT WEIGHTS.**

**⚠ WARNING**

SELECT LIFTING EQUIPMENT WITH CAPACITY CAPABLE OF SAFELY SUPPORTING WEIGHT.

**1.9 CRITICAL STABILITY WEIGHTS.**

**⚠ WARNING**

DO NOT REPLACE ITEMS CRITICAL TO STABILITY WITH ITEMS OF DIFFERENT WEIGHT OR SPECIFICATION (FOR EXAMPLE: BATTERIES, FILLED TIRES, PLATFORM) DO NOT MODIFY UNIT IN ANY WAY TO AFFECT STABILITY.